

35057-TE

**6-digit LED Frequency Counter Module
RED DISPLAY**

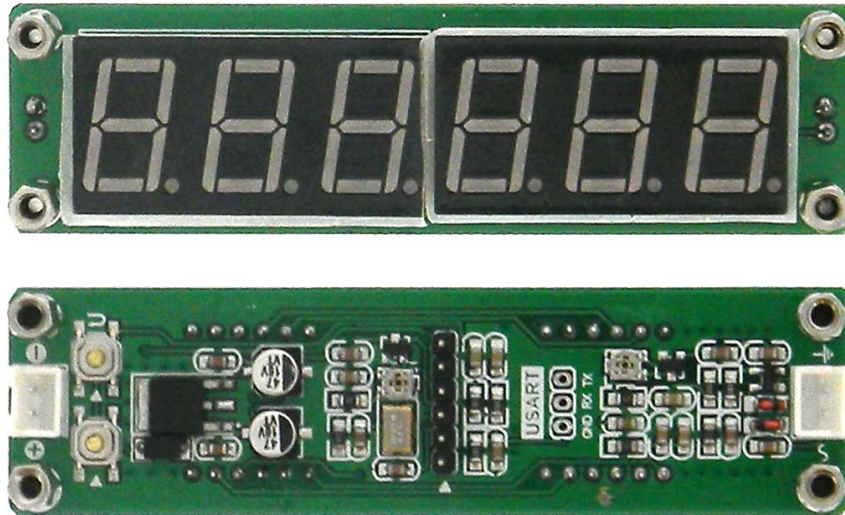

**PLJ-6LED-A LED
Frequency Display
Module Manual**

SANJIAN STUDIO™

Three Swords Studio

Light Rongsheng

2013, March

Guangxi • Nanning • Longan

Information including Links and Code (Software) Supplied or Referenced in this Document is supplied by MPJA inc. as a service to our customers and accuracy or usefulness is not guaranteed nor is it an Endorsement of any particular part, supplier or manufacturer. Use of information and suitability for any application is at users own discretion and user assumes all risk.

All rights are retained by the Owners/Author(s)

CONTENTS

Contents	2
Overview.....	2
Preparation	2
Technical Specifications.....	3
Layout	4
Operation and Use	5

OVERVIEW

The PLJ-6LED-A module is a cost-effective 8-digit frequency counter and display module primarily to display the operating frequency in a transceiver and other equipment. It may also be used for conventional frequency measurement. The module offers compact, reliable high performance with clear display at low cost.

Main Features include:

- *Microchip PIC16F628A 65MHz Processor*
- Frequency reference using a temperature-compensated voltage controlled crystal oscillator (2.5 ppm VC-TCXO). Unique gate control with precise time algorithm (No timer interrupt).
- The gate (display refresh) time is 0.1 seconds and the frequency value is displayed in real time
- The frequency measurement accuracy is 10Hz/100Hz (shifting one bit to the right) is optional
- Dual IF design, IF +/- offset value can be set
- Six-digit 0.56-inch LED display, 8 level adjustable brightness with automatic zero blanking
- Simple operation, 2 Button Control
- Settings are saved automatically and directly recalled at power-up

PREPARATIONS & PRECAUTIONS

NOTE: Check the Polarity of the Power & Input Pigtails! Do Not go by color alone:
1 Pigtail is Pinned for Power the other is for the Signal Input

CHECK THE SYMBOLS ON THE BOARD

Power:+Red/-Black Signal Input "S" Red /Gnd symbol Black

- Do not place the instrument in a hot, humid, dusty environment
- Do not subject to severe shock or vibration.
- The clock reference has been factory calibrated with a cesium atomic clock.
- Under Normal conditions adjustments are not required.
- The sensitivity has been factory adjusted to the optimal state.
Do not adjust it by yourself

TECHNICAL SPECIFICATIONS

1. GATE TIME

- 0.10 sec

2. INPUT

- High Impedance
- Measurement Range: 0.1MHz~ 65MHz
- Resolution: 10Hz
- Sensitivity: >60mVpp

3. IF SETTINGS

- Independent double-IF design allows the IF settings to be adjusted in minimum increments of 100 Hz.
- Intermediate frequency range: 0-99.9999MHz
- Offset: Select Plus or minus IF Offset (Add to Input Frequency or Subtract from

4. FREQUENCY REFERENCE

- 13.000MHz temperature compensated voltage controlled crystal oscillator (VC-TCXO)
- Frequency stability: ± 2.5 ppm

5. SUPPLY

- DC Input: 8V - 15V (Reverse polarity protection) Can be modified for 5VDC (No Polarity Protection)
- Current: 90 mA max (Test conditions: 12VDC supply, red LED display, brightness=8)

6. DISPLAY

- Six common anode 0.56in. 7-segment LED displays
- Eight adjustable LED brightness levels, factory set to the highest brightness

7. PHYSICAL

- Dimensions: (L×W×H): 91 X 28 X 20mm
- Weight: 46g net

8. CONNECTIONS

- RF Signal Input: HX2.54-2P
- DC Power: HX2.54-2P
- Program Port: 2.54-6P Header (Factory Use)

OPERATION AND USE

1. MODULE ARRANGEMENT



PCB Front
(May not Be Exact)

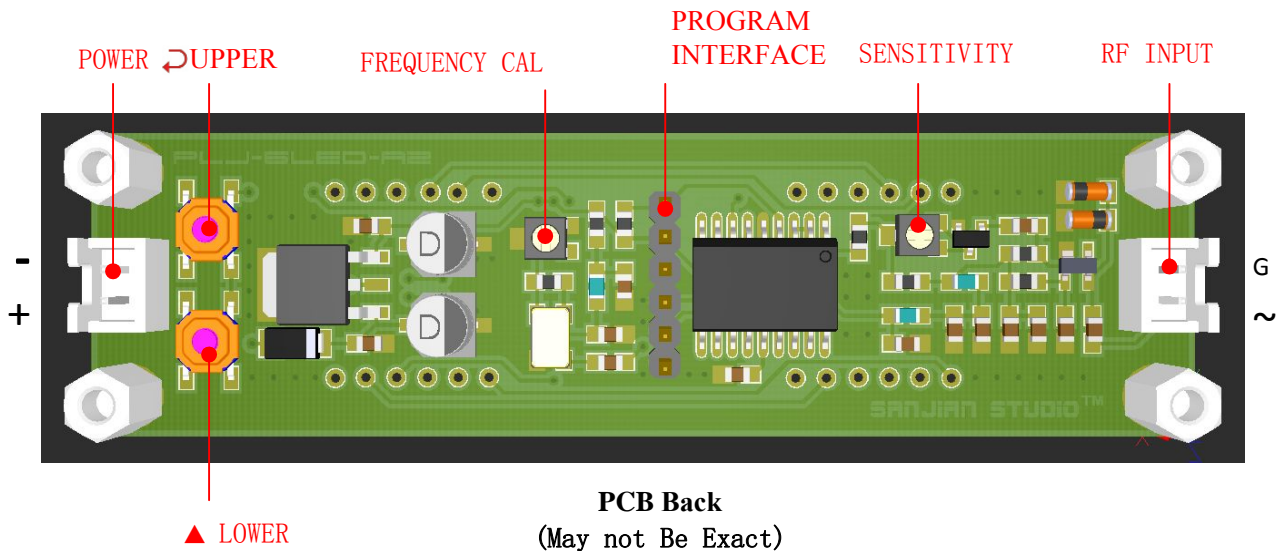

PCB Back
(May not Be Exact)

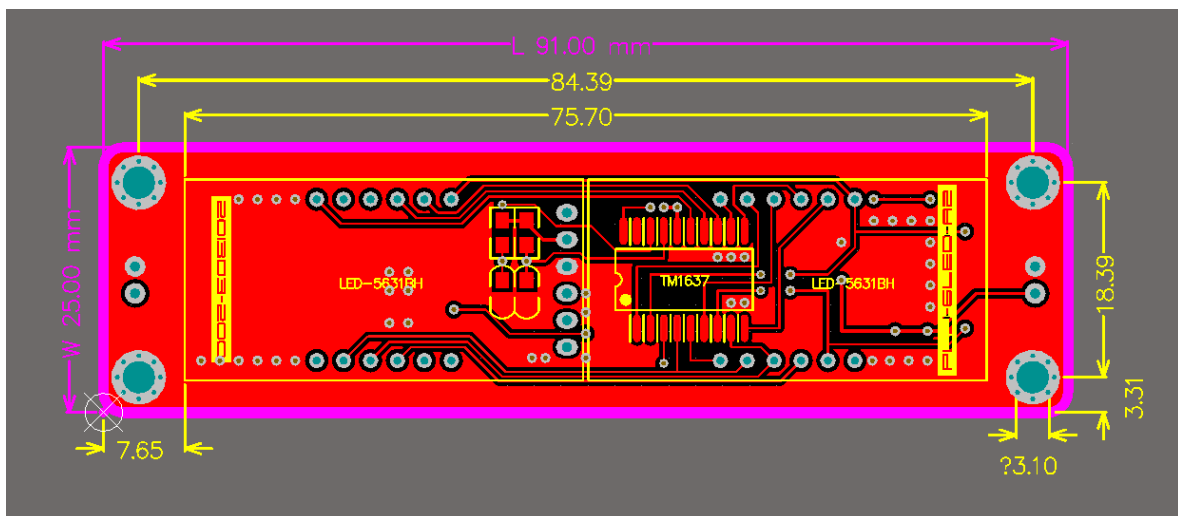

Mechanical

OPERATION AND USE

1. PARAMETER SETUP

“LOWER ▲” : Lower Button on Back “UPPER ↵” : Upper Button on Back

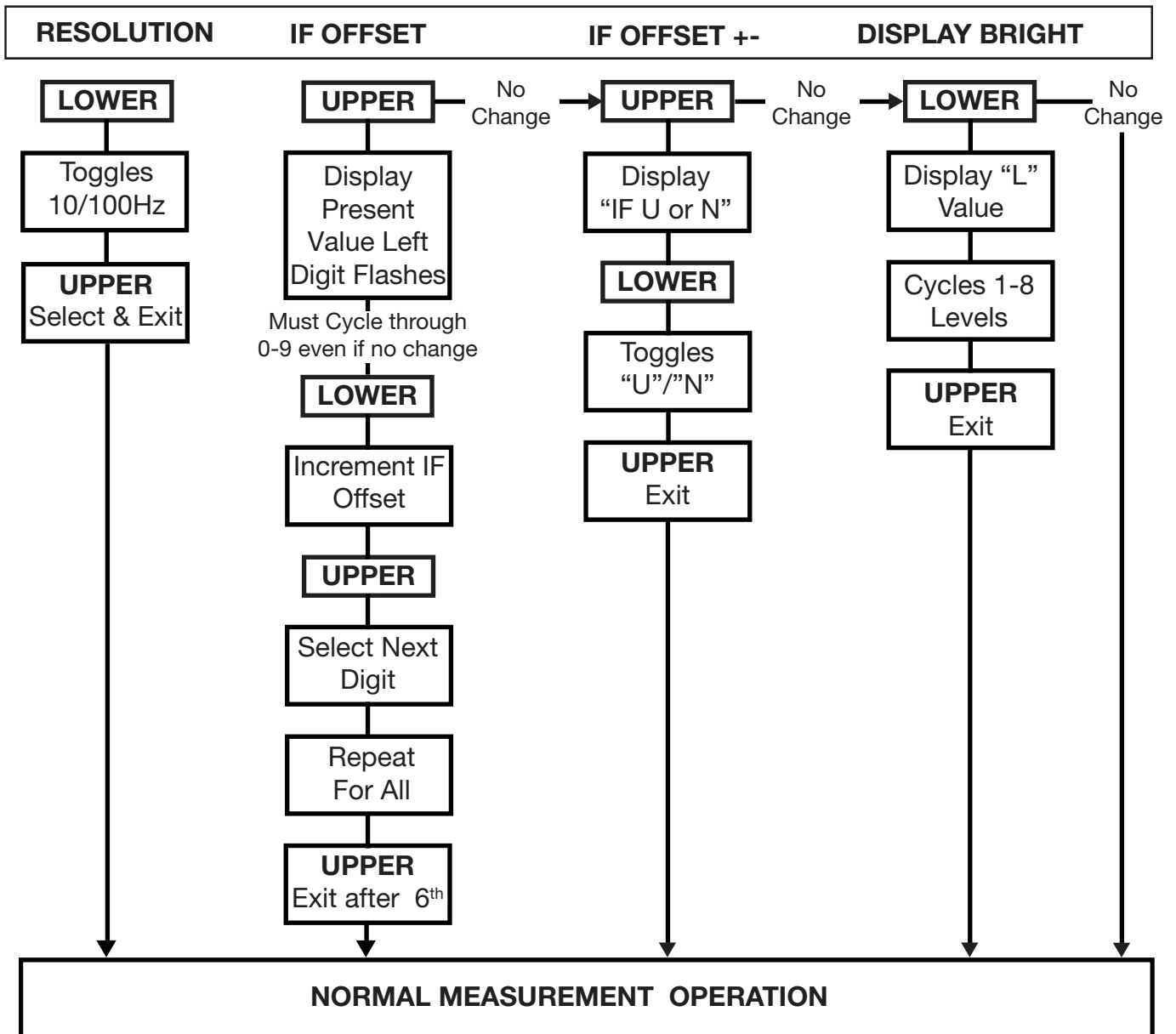

Resolution (Shift one Digit right)

